

Parts Illustration

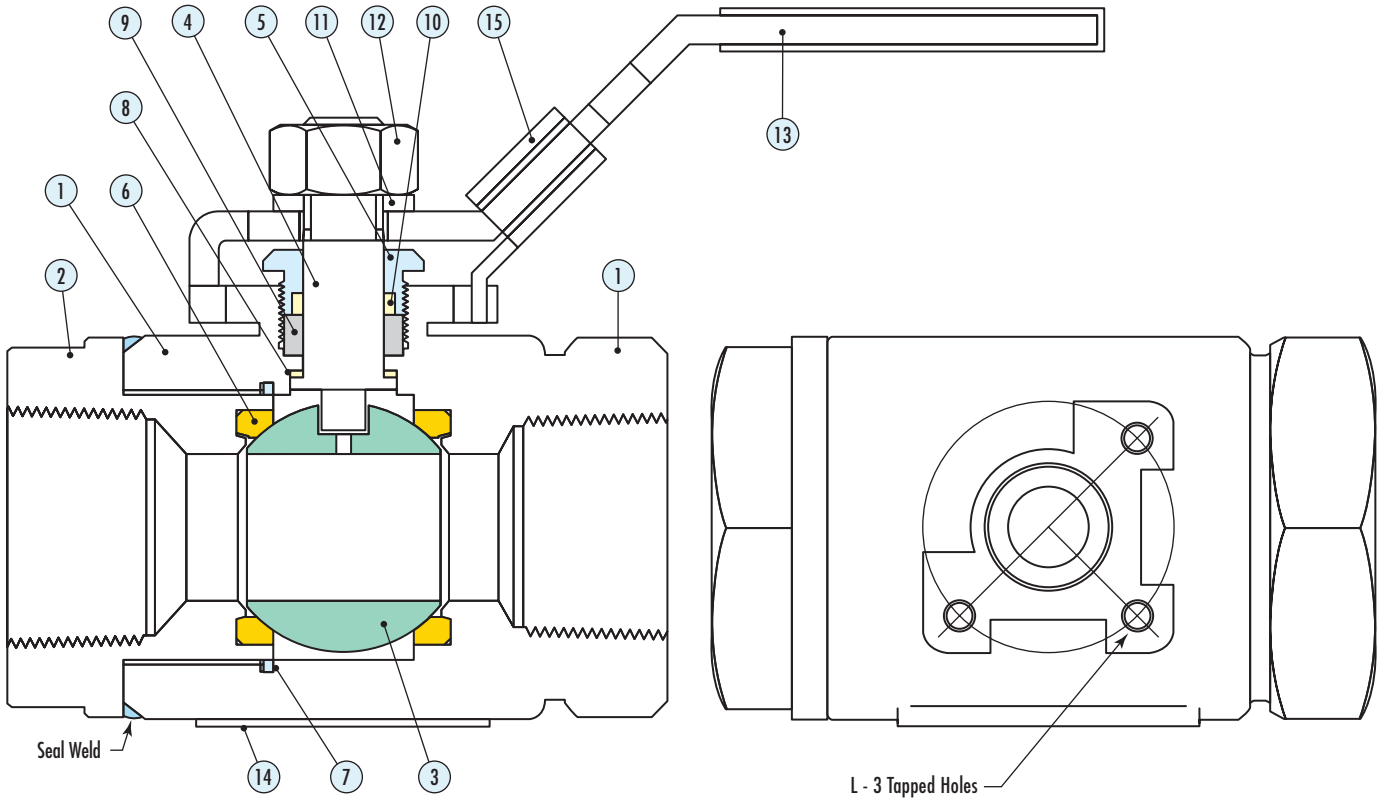

Parts & Materials

Part No	Qty	Part Name	Material Carbon Steel	Material Stainless Steel
1	1	Body	WCB	CF8M
2	1	Tailpiece	WCB	CF8M
3	1	Ball	CF8M	CF8M
4	1	Stem	S.S. 316	S.S. 316
5	1	Gland	S.S. 316	S.S. 316
6	2	Ball Seat	PTFE	PTFE
7	1	Tailpiece Seal	Graphite	Graphite
8	1	Thrust Washer	PTFE	PTFE
9	1	Stem Packing	Graphite	Graphite
10	1	Gland Bushing	PTFE	PTFE
11	1	Spring Washer	S.S. 304	S.S. 304
12	1	Handle Nut	S.S. 304	S.S. 304
13	1	Handle	S.S. 304	S.S. 304
14	1	Name Plate	S.S. 304	S.S. 304
15	1	Locking Device	S.S. 304	S.S. 304

Pressure Temperature

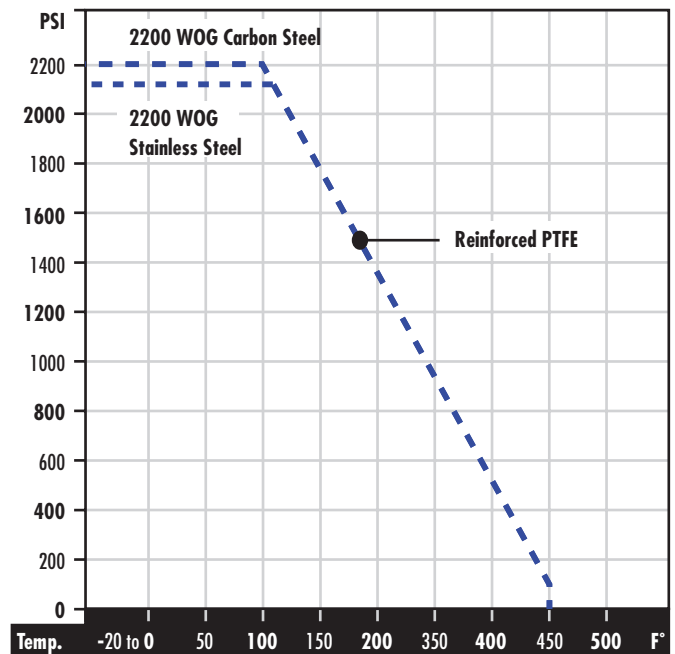

Break Torques (in.-lbs.)

Size (in.)						
1/4 - 3/8	1/2	3/4	1	1 1/4	1 1/2	2
39	74	123	135	248	300	321