

# Series 5312 Unibody Threaded Ball Valves

## The PBV® Series C5312/S5312 Unibody Threaded Floating Ball Valves

### Standard Features

- 2000 WOG
- Unibody Construction
- Blow-Out Proof Stem
- Virgin PTFE Seats/Graphite Seals
- Solid 316 Stainless Steel Ball and Stem
- Slotted Seat To Equalize Cavity Pressure
- Meets NACE MR0175 2002
- Firesafe To API 607 Specifications
- Locking Handle

### Available Options

- Oval Handle



### Dimensional Data

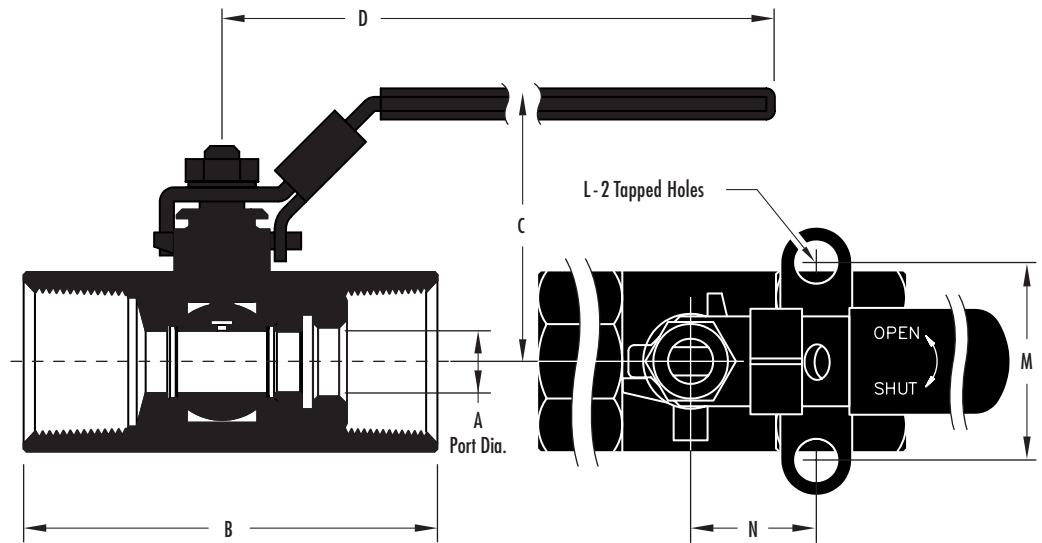

5312 Dimensional Data (in.), C<sub>v</sub> Data and Weight (lbs.) ■ 1/4"-2"

| Size (in.) | Dimensions |      |      |      |                  |       |       | C <sub>v</sub> | Appx. Wt. (lbs.) |
|------------|------------|------|------|------|------------------|-------|-------|----------------|------------------|
|            | A          | B    | C    | D    | L=2 Tapped Holes | M     | N     |                |                  |
| 1/4        | .31        | 2.45 | 1.50 | 4.41 | #10-24           | 1.125 | 0.500 | 4.00           | .60              |
| 3/8        | .31        | 2.45 | 1.50 | 4.41 | #10-24           | 1.125 | 0.500 | 4.00           | .60              |
| 1/2        | .31        | 2.50 | 1.50 | 4.41 | #10-24           | 1.125 | 0.500 | 5.20           | .62              |
| 3/4        | .43        | 2.88 | 1.73 | 5.00 | #10-24           | 1.375 | 0.875 | 10.00          | .75              |
| 1          | .59        | 3.33 | 2.20 | 5.51 | #10-24           | 1.375 | 0.875 | 22.00          | 1.25             |
| 1 1/2      | .93        | 4.06 | 2.91 | 7.01 | 1/4 - 20         | 1.500 | 0.930 | 44.00          | 3.25             |
| 2          | 1.18       | 4.52 | 3.15 | 7.01 | 1/4 - 21         | 1.500 | 0.930 | 73.00          | 4.75             |