

PBV® Z3

Three-Piece metal seated double block and bleed ball valves for severe service applications.

- .65"-3" Bore Size
- 1/2"-4" Nominal Pipe Size
- 150-1500 ANSI Class
- Available in SW, BW, FLG and NPT Ends
- Materials: A-105, F-22, F-91, 316 and others upon request

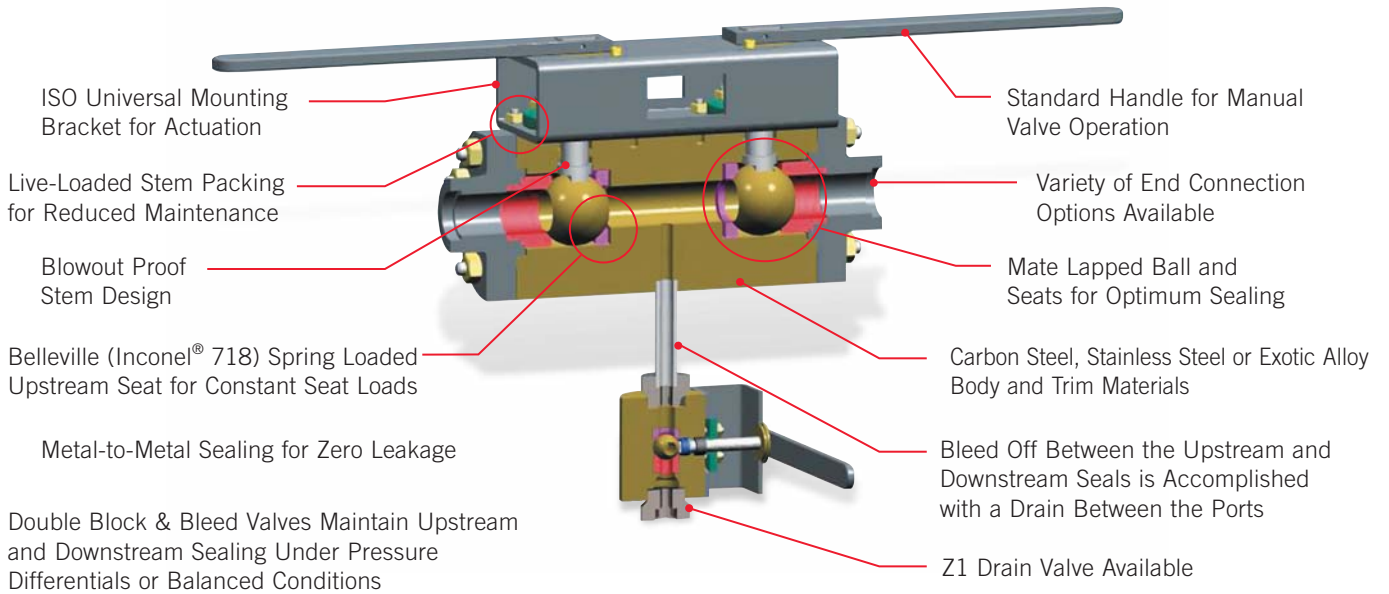

Rugged Design For All of Your Industrial Applications

PBV®'s Series Z3 Double Block & Bleed Metal Seated Severe Service Ball Valve is designed for dependable performance including Clean Critical Service, Oil & Gas Refining, Petroleum & Petro Chemical Production and many others. With two isolation points for zero leakage, the Z3 is designed to maintain upstream and downstream sealing under pressure differentials or balanced conditions.

Union Tech offers the Z3 Double Block & Bleed Metal Seated Severe Service Ball Valve in a variety of sizes and materials to meet your specific application requirements. Contact your PBV® Union Tech Representative today for more information about Series Z3 Ball Valves.