

PBV® Z1

One-Piece metal seated ball valves for high-pressure severe service applications including Power Generation and critical on/off applications.

- .65"-3" Bore Size
- 1/2"-4" Nominal Pipe Size
- 150-4500 ANSI Class
- 4 Year Warranty
- Design Meets ASME TDP-1 2006 Bore Requirements
- Material-A105, F22, F91 and 316 SS

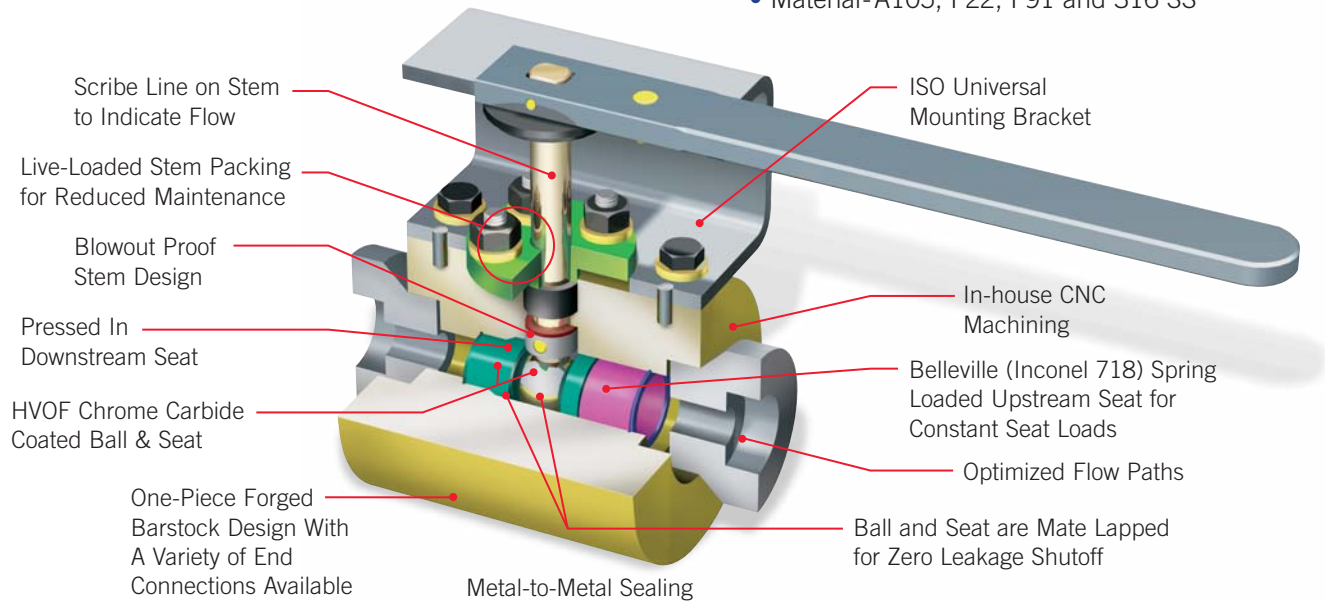

Dependable Performance For All of Your Power Applications

PBV's Series Z1 Metal Seated Severe Service Ball Valve is designed for dependable zero leakage performance in high pressure, high temperature, clean critical steam applications.

Union Tech offers the Z1 Severe Service Ball Valve in a variety of sizes and materials to meet your specific application requirements. Contact your PBV® Union Tech Representative today for more information about PBV® Severe Service Ball Valves.

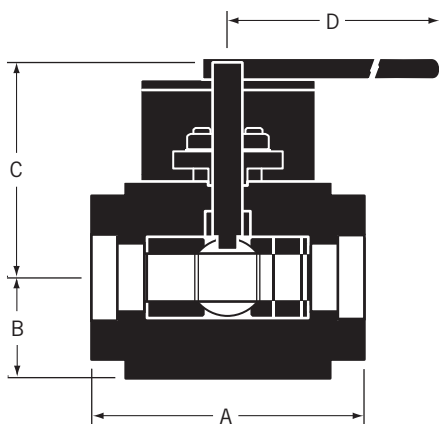

End Configuration Dimensions

NOTE: From Centerline of Valve.

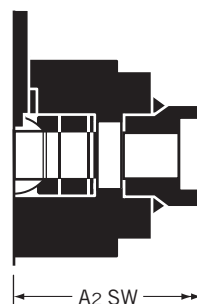
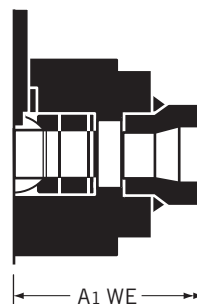

Dimensional Data

Bore Size (in.)	A	A1 WE	A2 SW	B	C	D	Weight (Lbs)
.65	5.00	4.50	3.50	2.25	5.00	13.25	25
1.00	6.00	5.00	4.00	2.75	5.50	19.25	46
1.40	8.00	6.00	5.50	3.00	5.75	19.25	66
1.75	9.50	7.25	6.25	3.25	6.00	24.00	98
2.00	12.25	8.13	6.25	4.25	7.75	NA	170
2.50	14.00	*	9.50	5.50	10.50	NA	**
3.00	14.50	*	9.00	5.25	11.00	NA	**

*Consult factory for dimensions not listed. **Consult factory for weights not listed.