

# Zy-Gear WG208 Worm Gear Operator

## Parts And Materials

Item	Part Name	Material
1	Cover	Carbon Steel
2	O-Ring	Nitrile
3	Lock Screw	Carbon Steel
4	Stop Screw	Carbon Steel
6	Hex Bolt	Carbon Steel
7	End Cap	Carbon Steel
8	Bearing	PTFE and Carbon Steel
9	Thrust Bearing	Commercial
10	Worm	AISI 4135
11	Grease Fitting	Brass
12	Pin	Carbon Steel
13	Input Shaft	AISI 4135
14	O-Ring	Nitrile
15	Lock Bracket	Carbon Steel
17	Key	Carbon Steel
18	Lock Plate	Carbon Steel
20	Square Nut	Carbon Steel
21	Handwheel	Carbon Steel
22	O-Ring	Nitrile
23	O-Ring	Nitrile
24	Indicator Plate	Cast Iron
26	Cover	Cast Iron
27	Gasket	Rubber
28	Worm Gear	Ductile Iron
29	Housing	Cast Iron

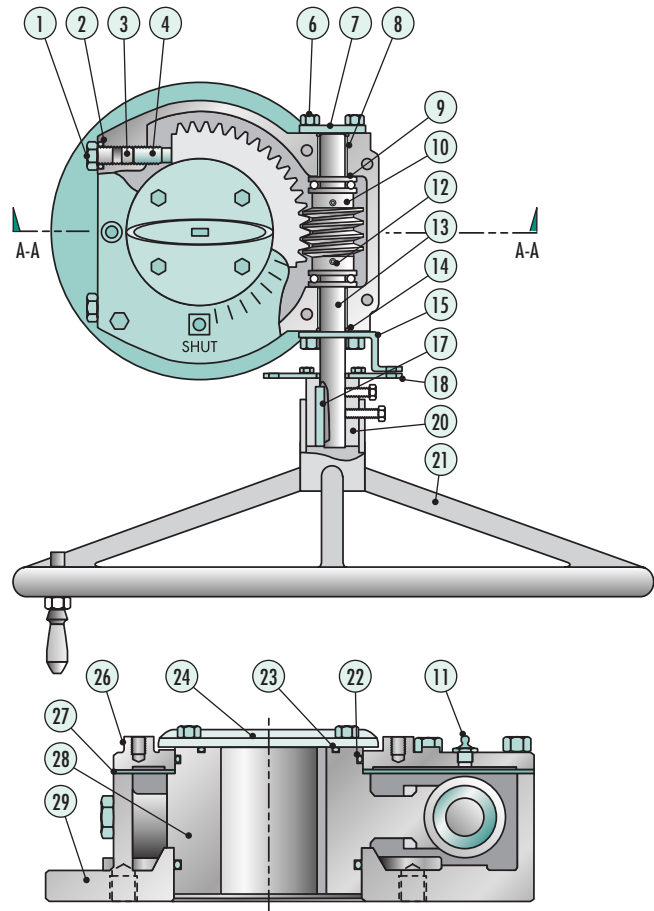

SECTION A-A

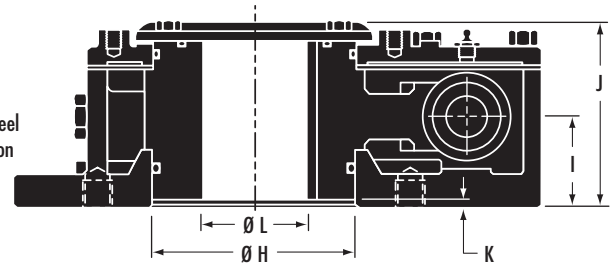
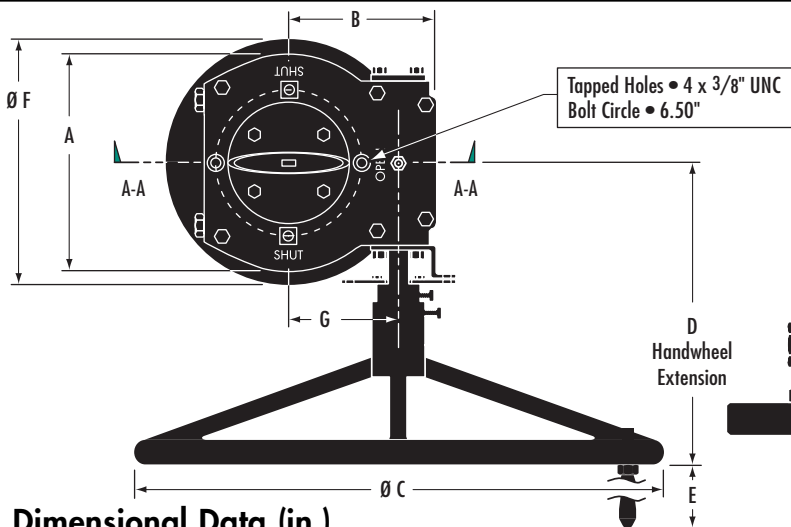

SECTION A-A

## Dimensional Data (in.)

Model	Wt. (lb.)*	A	B	C	D	E	F	G	H	I	J	K	L
WG208	88	9.90	6.70	18	13.6	4.00	11.20	4.96	4.72	2.13	4.33	0.20	1.5
				24	17.1								
				30	15.9								

\*Approximate weight without handwheel.