

Series 6400 Full Port Dimensional Data, Class 150, 300 & 600

Dimensional Data (in.)

Test Pressure	Shell (hydrostatic)	Seat (air)
Class 150	450 psi	80 psi
Class 300	1125 psi	80 psi
Class 600	2250 psi	80 psi

Series 6400, 1/2"-1", Class 150, 300 & 600 (in.)

Valve Size	A	C	D	E	F	G	NxøH	I	J	L
Class 150, 1/2"-1"										
1/2	0.49	1.38	3.50	0.06	0.44	4.25	4 x ø.62	2.38	4.38	5.12
3/4	0.71	1.69	3.88	0.06	0.44	4.62	4 x ø.62	2.75	4.53	5.12
1	0.97	2.00	4.25	0.06	0.44	5.00	4 x ø.62	3.12	5.63	6.32
Class 300, 1/2"-1"										
1/2	0.49	1.38	3.75	0.06	0.56	5.50	4 x ø.62	2.62	4.38	5.12
3/4	0.71	1.69	4.62	0.06	0.62	6.00	4 x ø.75	3.25	4.53	5.12
1	0.97	2.00	4.88	0.06	0.69	6.50	4 x ø.75	3.50	5.63	6.32
Class 600, 1/2"-1"										
1/2	0.49	1.38	3.75	0.25	0.82	6.50	4 x ø.62	2.62	4.38	5.12
3/4	0.71	1.69	4.62	0.25	0.87	7.50	4 x ø.75	3.25	4.53	5.12
1	0.97	2.00	4.88	0.25	0.95	8.50	4 x ø.75	3.50	5.63	6.32

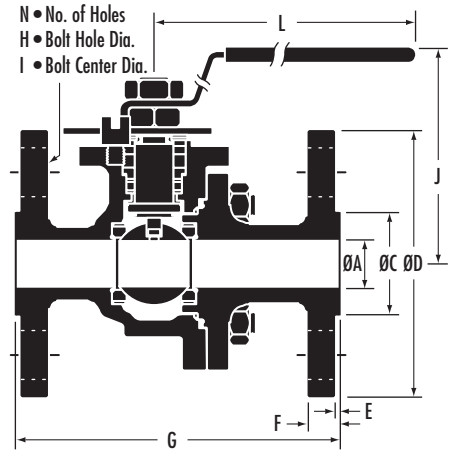

Series 6400, 1 1/2"-2", Class 150, 300 & 600 (in.)

Valve Size	A	C	D	E	F	G	NxøH	I	J	L
Class 150, 1 1/2"-2"										
1 1/2	1.50	2.88	5.00	0.06	0.56	6.50	4 x ø.62	3.88	5.81	9.00
2	2.00	3.62	6.00	0.06	0.62	7.00	4 x ø.75	4.75	6.95	16.50
Class 300, 1 1/2"-2"										
1 1/2	1.50	2.88	6.12	0.06	0.81	7.50	4 x ø.88	4.50	5.81	9.00
2	2.00	3.62	6.50	0.06	0.88	8.50	4 x ø.75	5.00	6.95	16.50
Class 600, 1 1/2"-2"										
1 1/2	1.50	2.88	6.12	0.25	1.13	9.50	4 x ø.88	4.50	5.81	9.00
2	2.00	3.62	6.50	0.25	1.28	11.50	4 x ø.75	5.00	6.95	16.50

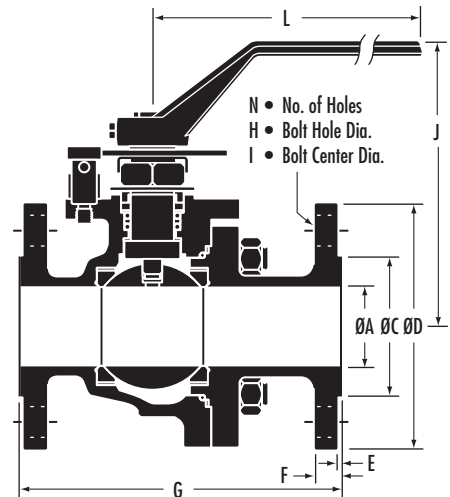

Series 6400, 3"-10", Class 150, 300 & 600 (in.)

Valve Size	A	C	D	E	F	G	NxøH	I	J	L
Class 150, 3"-10"										
3	3.00	5.00	7.50	0.06	0.75	8.00	4 x ø.75	6.00	7.80	16.50
4	4.00	6.19	9.00	0.06	0.94	9.00	8 x ø.75	7.50	8.71	19.70
6	6.00	8.50	11.00	0.06	1.00	15.50	8 x ø.88	9.50	11.69	43.00
8	8.00	10.62	13.50	0.06	1.12	18.00	8 x ø.88	11.75	14.60	58.00
10	10.00	12.75	16.00	0.06	1.19	21.00	12 x ø1.00	14.25	—	—
Class 300, 3"-10"										
3	3.00	5.00	8.25	0.06	1.12	11.12	8 x ø.88	6.62	7.80	16.50
4	4.00	6.19	10.00	0.06	1.25	12.00	8 x ø.88	7.88	8.71	19.70
6	6.00	8.50	12.50	0.06	1.44	15.88	12 x ø.88	10.62	11.69	43.00
8	8.00	10.62	15.00	0.06	1.62	19.75	12 x ø1.00	13.00	14.60	58.00
10	10.00	12.75	17.50	0.06	1.88	22.38	16 x ø1.12	15.25	—	—
Class 600, 3"-4"										
3	3.00	5.00	8.25	0.25	1.50	14.00	8 x ø.88	6.62	8.06	19.70
4	4.00	6.19	10.75	0.25	1.75	17.00	8 x ø1.00	8.50	10.60	43.00

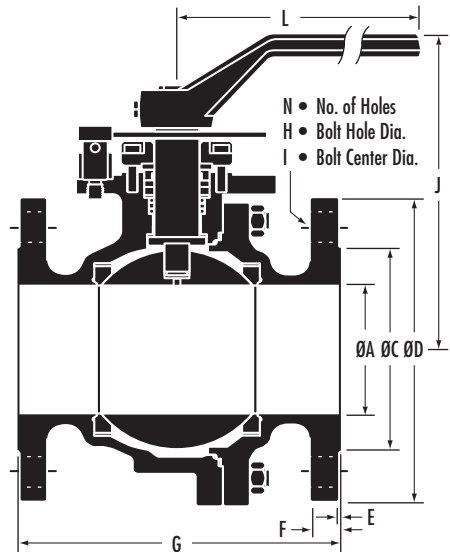

Note: 6"-10" Optional gear operation.