

Series 4400 Regular Port Dimensional Data, Class 150, 300 & 600

Dimensional Data (in.)

Test Pressure	Shell (hydrostatic)	Seat (air)
Class 150	450 psi	80 psi
Class 300	1125 psi	80 psi
Class 600	2250 psi	80 psi

Series 4400, 3/4"-1 1/2", Class 600 (in.)

Valve Size	A	B	C	D	E	F	G	NxØH	I	J	L
	Class 600, 3/4"-1 1/2"										
3/4	0.50	0.78	1.69	4.62	0.25	0.87	7.50	4xØ.75	3.25	5.00	5.12
1	0.72	0.98	2.00	4.88	0.25	0.94	8.50	4xØ.75	3.50	5.12	5.12
1 1/2	0.97	1.57	2.88	6.12	0.25	1.13	9.50	4xØ.88	4.50	5.65	6.32

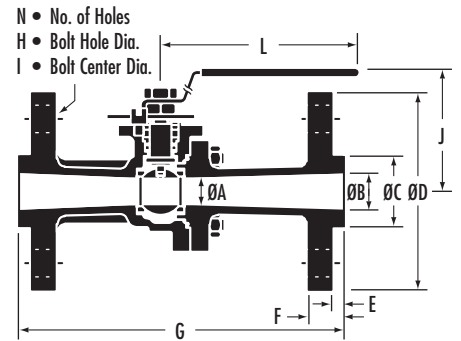

Series 4400, 2"-3", Class 150, 300 & 600 (in.)

Valve Size	A	B	C	D	E	F	G	NxØH	I	J	L
	Class 150, 2"-3"										
2	1.50	2.00	3.62	6.00	0.06	0.62	7.00	4xØ.75	4.75	5.81	9.00
3	2.00	3.00	5.00	7.50	0.06	0.75	8.00	4xØ.75	6.00	6.95	16.50
Class 300, 2"-3"											
2	1.50	2.00	3.62	6.50	0.06	0.88	8.50	8xØ.75	5.00	5.81	9.00
3	2.00	3.00	5.00	8.25	0.06	1.12	11.12	8xØ.88	6.62	6.95	16.50
Class 600, 2"-3"											
2	1.50	2.00	3.62	6.50	0.25	1.28	11.50	8xØ.75	5.00	5.81	9.00
3	2.00	3.00	5.00	8.25	0.25	1.50	14.00	8xØ.88	6.62	6.95	16.50

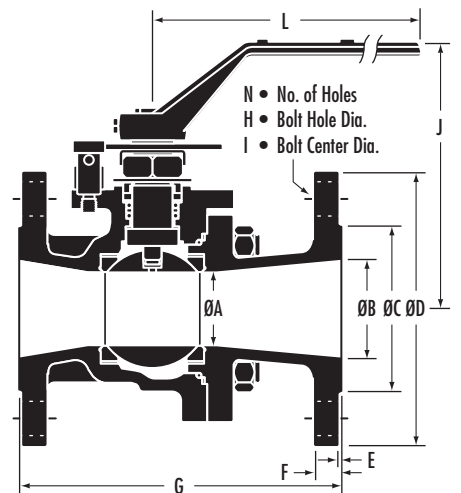

Series 4400, 4"-10", Class 150, 300 & 600 (in.)

Valve Size	A	B	C	D	E	F	G	NxØH	I	J	L
	Class 150, 4"-10"										
4	3.00	4.00	6.19	9.00	0.06	0.94	9.00	8xØ.75	7.50	7.80	16.50
6	4.00	6.00	8.50	11.00	0.06	1.00	15.50	8xØ.88	9.50	8.71	19.70
8	6.00	8.00	10.62	13.50	0.06	1.12	18.00	8xØ.88	11.75	11.70	43.00
10	8.00	10.00	12.75	16.00	0.06	1.19	21.00	12xØ.100	14.25	14.60	58.00
Class 300, 4"-10"											
4	3.00	4.00	6.19	10.00	0.06	1.25	12.00	8xØ.88	7.88	7.80	16.50
6	4.00	6.00	8.50	12.50	0.06	1.44	15.88	12xØ.88	10.62	8.71	19.70
8	6.00	8.00	10.62	15.00	0.06	1.62	19.75	12xØ.100	13.00	11.70	43.00
10	8.00	10.00	12.75	17.50	0.06	1.88	22.38	16xØ.112	15.25	14.60	58.00
Class 600, 4"-6"											
4	3.00	4.00	6.19	10.75	0.25	1.75	17.00	8xØ.100	8.50	8.06	19.70
6	4.00	6.00	8.50	14.00	0.25	2.14	22.00	12xØ.112	11.50	10.60	43.00

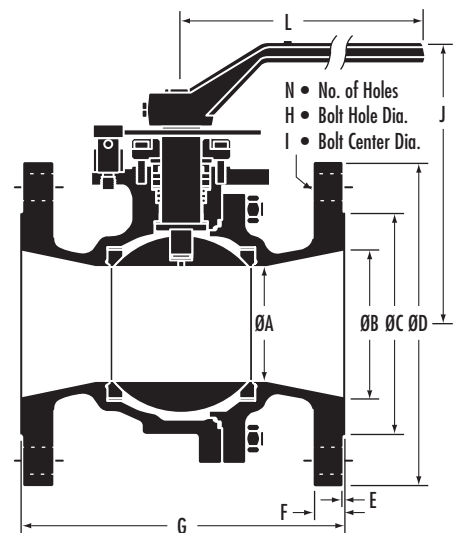

Note: 6"-10" Optional gear operation.