

## Materials of Construction

PBV® manufactures trunnion ball valves using a full range of carbon, alloy and stainless materials. Our commodity valves are manufactured using dual rated A105/A350 LF2 steel, B7M/2HM fasteners, and 3 mil ENP carbon steel trim on 6" and larger. Material test reports in accordance with EN10204 3.1b are available on each serialized valve.

## NACE Compliance

The demand for valves to be resistant to sulfide stress cracking, and to perform in corrosive hydrocarbon environments, has become commonplace. Facilities handling H<sub>2</sub>S bearing hydrocarbons have increased dramatically over recent years. Hydrogen sulfide concentration, total system pressure, application temperature, existence of elemental sulfur, and chloride content all have a bearing on appropriate material selection in this severe environment.

All materials used by PBV® are in accordance with the pre-qualified materials identified in NACE MR0175/ISO 15156. In order to ensure compliance customers must provide application specific operating conditions.

Inclusive to the above, valves with bore diameters 4" and smaller are supplied standard with Stainless Steel balls, seats and stems. Material type selected may vary depending on design requirements.

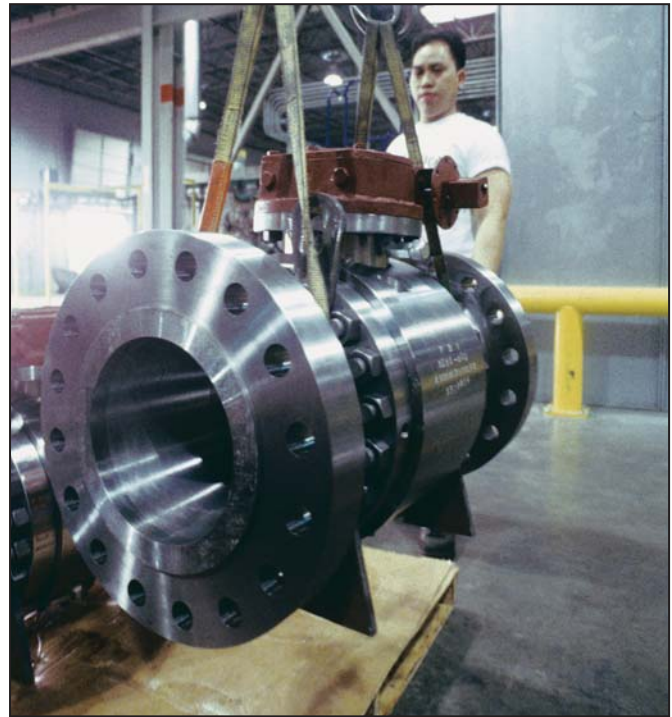

## Emergency Sealant Injection

A secondary sealant injection system for stem seals is a standard feature on all PBV® trunnion ball valves. On valves 6" bore and larger, the seat emergency sealant system shown here is a standard feature. A similar system is available for sizes 2" thru 4" on request.

These systems are made available for the sole purpose of providing a temporary seal to an otherwise damaged area. PBV® ball valves require no lubrication under ordinary circumstances.

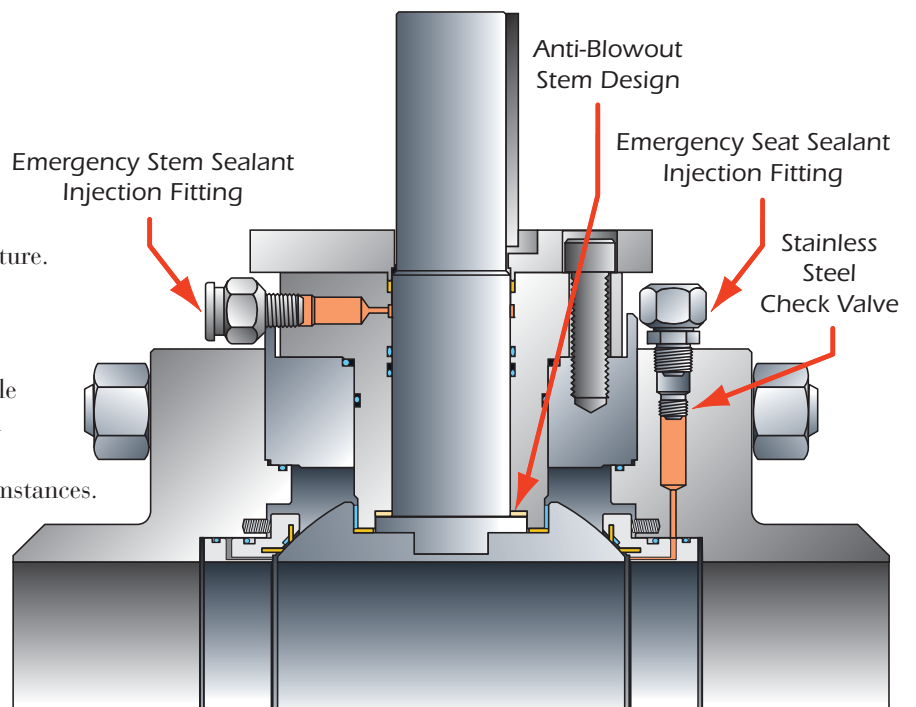

## Anti-Blowout

Blowout proof stems are a standard feature of all PBV® ball valves.

## PBV®'s Patented Seat Technologies

PBV® provides the latest in valve seat technology, leading the industry with the patented Comp II seat. Other seat designs are also available to meet your application requirements. This makes PBV® one of the most flexible manufacturers in

terms of available seat configurations and designs. PBV®'s metal-to-metal seating technologies and manufacturing capabilities continue to lead the way in industry innovations where severe service applications are required.

### Compseal-II 2"-12" Standard, Class 150-1500

PBV® has a patented seat design called Compseal II. This seat combines the strength and durability of hard plastics while providing the low pressure sealing capabilities of elastomers. The illustration shows the Compseal II seat insert locked into the seat retainer. Compseal II may be supplied in a variety of combinations of elastomers and plastics.

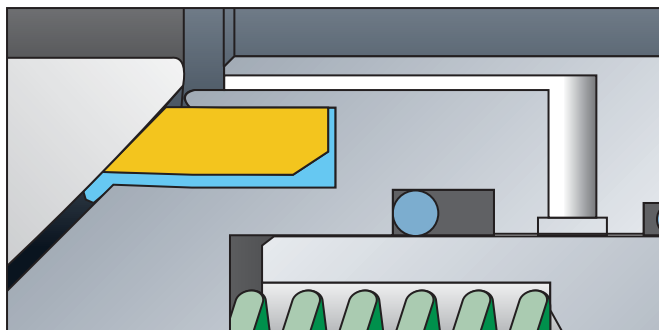

### Compseal-0 14" and Larger Standard, Class 600 and Up 2" and Larger Standard, Class 2500

The PBV® Compseal-0 design is ideal for applications where non-standard seat materials are required for the service conditions. The different materials give added flexibility for faster delivery in demanding applications. The seat inserts allow for a variety of materials to be used while still complying to API seat test requirements for "bubble-tight shut-off". Nylon Compseal-0 designs are standard on sizes 14" and larger.

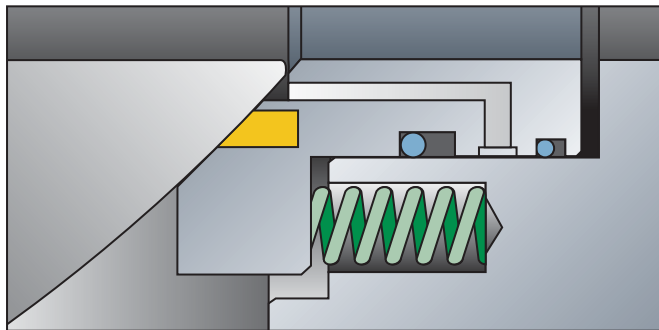

### Compseal-1 14" and Larger Standard, Class 150-300

PBV® Compseal-1 seat designs are for applications that require redundant sealing when access to a valve is limited or start up conditions are known to have debris in the line. Lower torque and low pressure shut-off are often achieved utilizing this design while providing customers with zero leakage reliability at an affordable price.

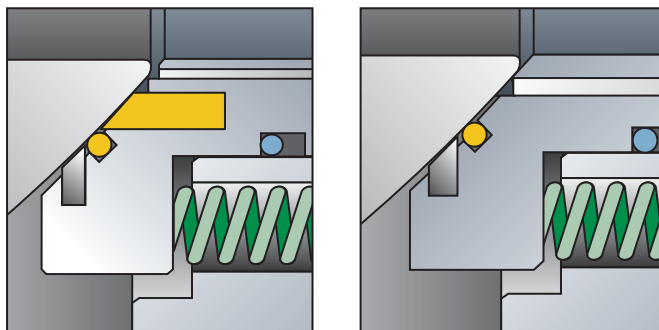

CMP-1

V-V

### Metal-To-Metal Seats

There are a number of services that require metal-to-metal seat technology. PBV® has extensive experience in the supply of valves for applications such as high temperature cokers, control valve applications and in corrosive and/or erosive environments. PBV® achieves the metal-to-metal seating technology through the use of various hard face material on the ball and seat face.

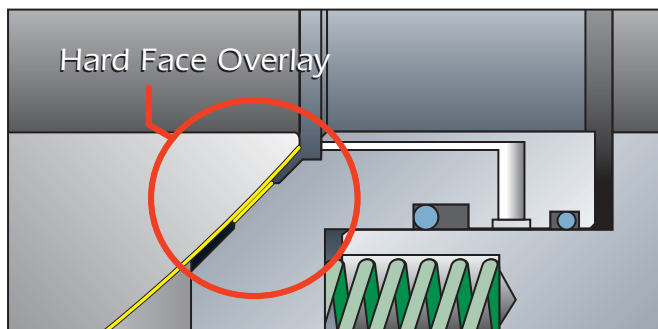

## Locking Devices

Locking devices are standard on all PBV® trunion ball valves. The designs shown depict the locking feature for both lever-operated and gear-operated valves. In addition, a multiple lock template can accommodate safety requirements when more than one person needs reassurance of security. Special safety interlock devices are also available.

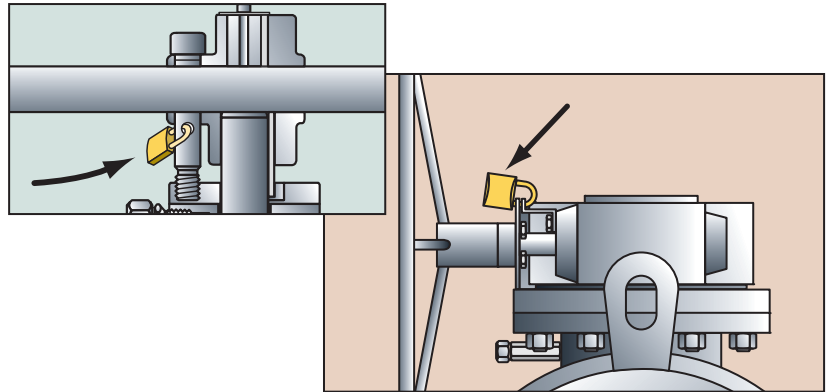

## Actuation

PBV® ball valves are built to easily accept pneumatic, electric, hydraulic or gas-over-oil actuators. Break-away and run torque, which normally affect actuator sizing, are minimized to allow for economical actuator packages. Actuated ball valves may be supplied directly from PBV® under a single warranty.

Valve/Actuator assemblies can be tested to customer requirements at PBV® before shipment to the job site.

*The valves shown at right are just a few of many severe service ball valves PBV® produced for the United States Department of Energy, Strategic Petroleum Reserves, complete with gear operators built and tested to DOE specifications.*

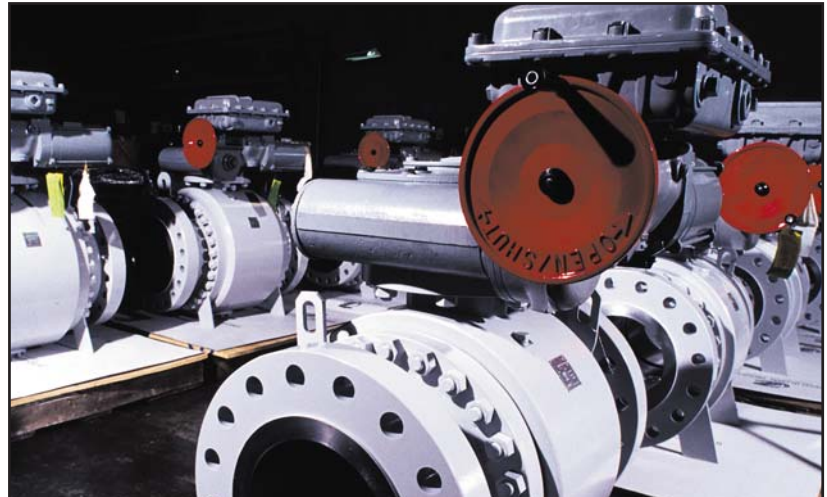

## Weld Overlay Technology

This technology is cost effective for ball valves in highly corrosive or erosive services. The life of a valve can be considerably extended at a fraction of the cost of a solid corrosion resistant alloy valve by the application of a weld overlay to valve internal surfaces.

If you are currently using solid stainless steel or other high alloy valves the use of this technology could result in considerable savings with no sacrifice to service life or performance. Offered on valves 6" and larger.

Welding is performed in accordance with ASME BPV Section 9.



### Three-Piece Trunnion Series 5700/6700 Double Block and Bleed Valves

All PBV® trunnion mounted ball valves are designed and manufactured to facilitate block and bleed applications in the closed position only. In addition, valves 6" and larger can be completely flushed with the valve under pressure and in the closed position. This is achieved by utilizing the drain valve and vent hole in combination. The illustration shows both the upstream pressure ( $P_u$ ) and the downstream pressure ( $P_d$ ) being held independently from the body pressure ( $P_b$ ). The piston effect principle illustrated assures bubble tight sealing simultaneously on both sides of the ball.

Shown In Closed Position

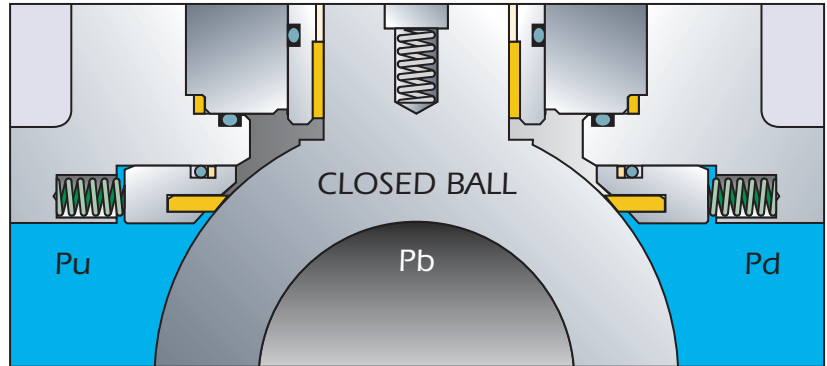

### Two-Piece Trunnion Series 6800 Double Block and Bleed Valves

The PBV® two-piece cast series 6800 trunnion ball valve has complete body cavity isolation from the media in both the open and closed position. The operator can perform a double block & bleed in the open or closed position to check seat seal integrity. Body cavity vent and drain ports are provided as standard to perform this inspection. The seats are self-relieving to automatically prevent over pressurization of the body cavity due to thermal expansion of the trapped fluid. When the body cavity pressure increases above the net spring load the seat moves away from the ball venting pressure downstream.

Shown In Open Position

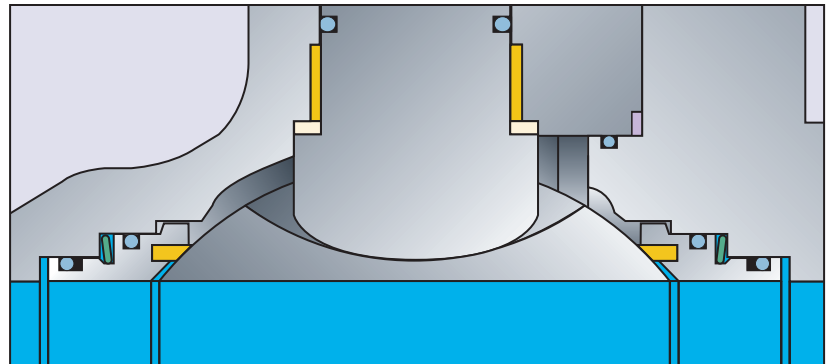

### Valve Cavity Pressure Relief

When a trunnion ball valve is in the closed position, media will be trapped in the body cavity. Unless this media is drained, it will be subjected to thermal expansion and contraction. As the temperature rises, the trapped media desires to expand and the pressure increases in the area shown as ( $P_b$ ). In order to avoid excessive pressure build-up, the PBV® seats are designed to self-relieve, allowing the media in the body to escape to the pipeline. In this case, we have shown it to relieve to the downstream side ( $P_d$ ). This self-relieving seat design feature is standard on all PBV® trunnion ball valves.

Shown In Closed Position

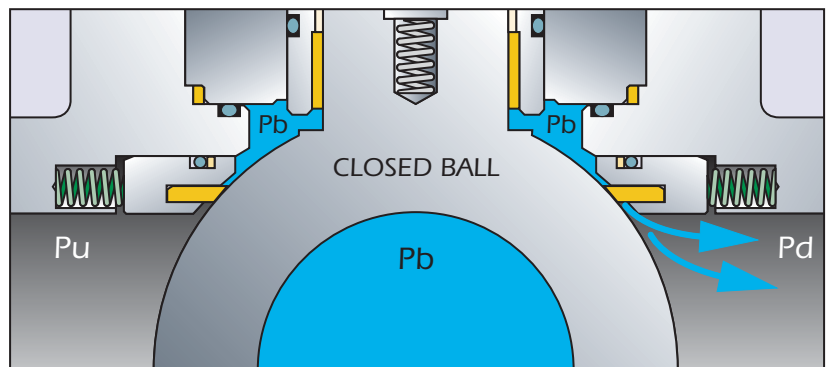

## Seat Design

The necessary thrust required for proper sealing of the seat to the ball at low pressure is provided by spiral springs (See Illustration 1). At high pressure the thrust of the seat to the ball is increased by the pressure of service medium in the pipeline. Primary seat sealing is provided by a soft sealing ring of different rubber types. Alternatively, a PTFE hard sealing ring (or PTFE modifications) can be used for primary sealing. Secondary sealing is provided by metal-to-metal contact of the seat to the ball. Emergency sealant, which can be injected between the seat and ball, can be used as tertiary sealing. Seats with soft sealing rings are automatically supplied as DPE design (See Illustration 2). DPE design means, that if the upstream seat is damaged, function of a ball valve is still secured by a downstream seat.

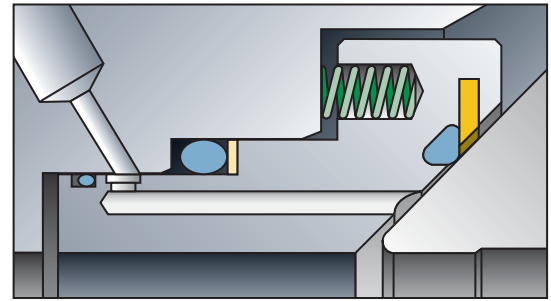
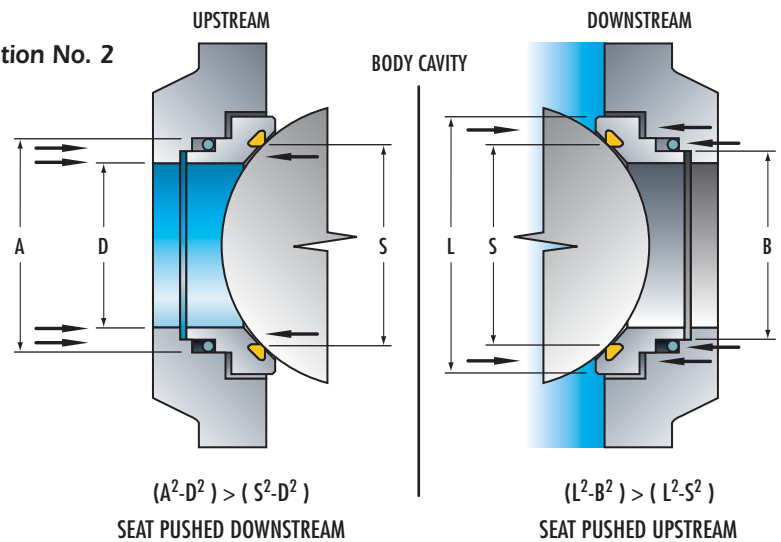

Illustration No. 1

Illustration No. 2



## Two-Way Double Block and Bleed

To meet customers requirements, often times a two-way seat design is required. This design allows for downstream seat sealing in the case of an upstream seat failing to seal. This design also provides for the function of testing a valve in-line and in full open position with the drain or bleed valve open to the air.

## Fully Welded Body Design

Fully welded three-piece body designs are available in larger sizes.

## Special Under Water Gas Testing

Valves can be air or gas tested under water in a special chamber.

