

Series 6700 ■ 2"-4" Class 150 ■ 2" Class 300

No.	Description	Material	Spares
1	Body	A105/A350 LF2	
2	Closure/Flanged End	A105/A350 LF2	
4	Ball	316SS	
5	Stem	316SS	
6	Seat Ring Sub Assembly	316SS- G/PTFE	S
9	Trunnion	4130 ENP	
10	Gland	4130 ENP	
12	Adapter Plate	A36	
20	Stem Key	Carbon Steel	
25	Stem Thrust Washer	Graphite	S
28	Ball Bearing	DU Dry Bearing	
31	Seat/Stem Spring	X-750	
32	Body O-ring	Viton®	S
33	Seat O-ring	Viton®	S
34	Stem O-ring	Viton®	S
35	Gland & Trunnion O-ring	Viton®	S
39	Body Cap Screw	A574 Modified	
43	Gland Cap Screw	A574 Modified	
44	Adapter Plate Cap Screw	A574 Modified	
45	Trunnion Cap Screw	A574 Modified	
46	Stem Key Cap Screw	Carbon Steel	
49	Stem Grease Fitting	Carbon Steel	
50	Body Grease Fitting	Carbon Steel	
51	Check Valve	Stainless Steel	
54	Drain Valve	Carbon Steel	
60	Handle	Ductile Iron	
62	Indicator Screw	Carbon Steel	
63	Retainer Washer	Carbon Steel	
64	Name Plate	Stainless Steel	
65	Drive Screw	Stainless Steel	
67	Handle Adapter	Carbon Steel	
69	Lock Screw	Carbon Steel	
70	Body Gasket	Graphite	S
71	Gland & Trunnion Gasket	Graphite	S
72	Stem Packing	Graphite	S

NOTE: Materials listed are typical for stainless steel trim valves. Stronger materials may be used to satisfy design requirements.

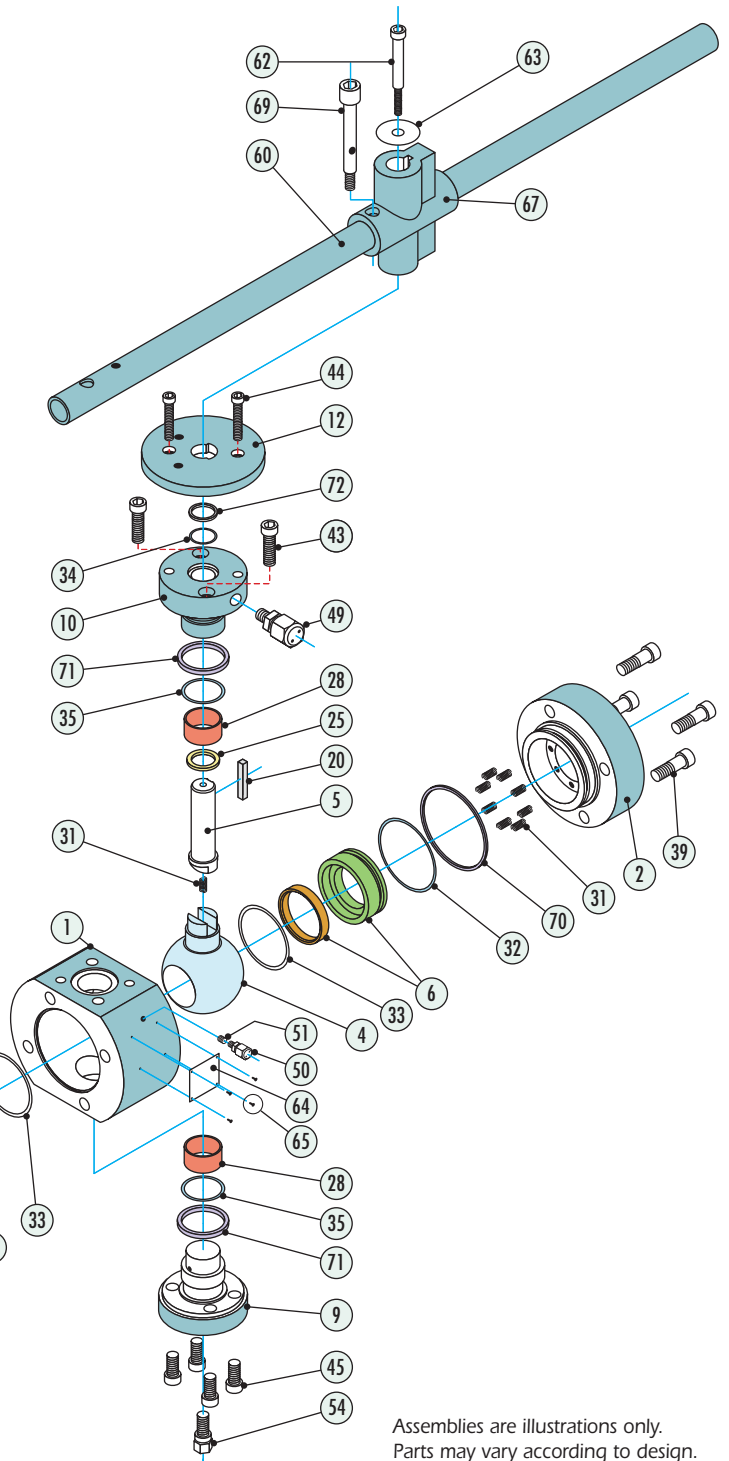

Assemblies are illustrations only. Parts may vary according to design.

Small Bore Valve Design Utilizes Tapped Holes In The End Flanges To Maintain API 6D Face-to-Face Specifications

Small diameter trunnion ball valves often require tapped holes on the end flanges in order to maintain the face to face dimensions specified in API 6D. The following full bore valves have tapped holes in accordance with API 6D instead of straight holes on both ends. The recommended stud length is listed at right.

**For Reference Only
Stud Length To Install Valve**

Bore Size	Stud Bolt Size	Quantity/Flange
2-150	5/8-11UNC X 2.25	4
3-150	5/8-11UNC X 2.38	4
4-150	5/8-11UNC X 2.50	8
2-300	5/8-11UNC X 2.50	8

Series 6700 ■ 2"-4" Class 150 ■ 2" Class 300

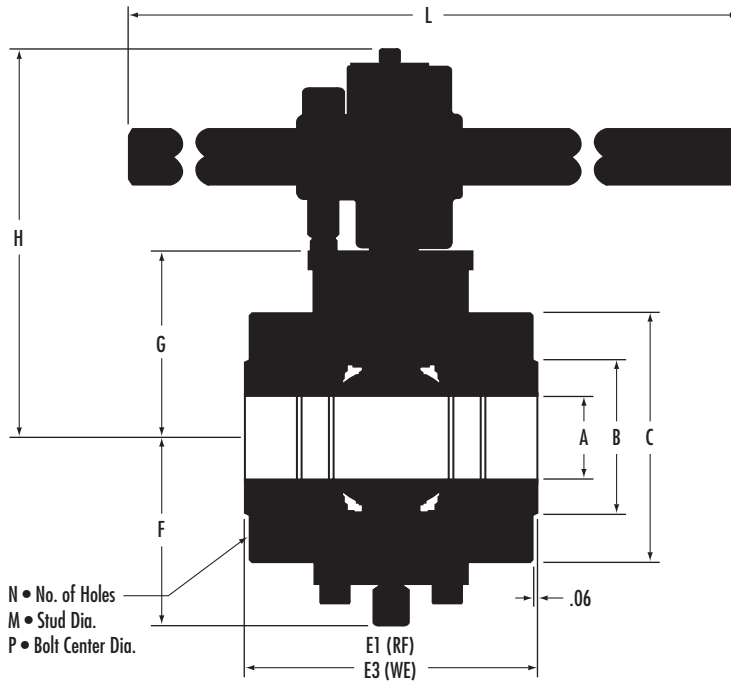

Class 150 2"FP-4"FP (in.)

Size	A	B	C	D1	E1-RF	E3-WE	F	G	H	N	M	P	L
2x2	2.00 x 2.00	3.62	6.00	NA	7.00	8.50	4.89	4.87	9.55	4	5/8-11UNC	4.75	30
3x3	3.00 x 3.00	5.00	7.87	NA	8.00	11.12	5.87	5.94	10.92	4	5/8-11UNC	6.00	30
4x4	4.00 x 4.00	6.19	9.49	NA	9.00	12.00	7.30	7.35	12.93	8	5/8-11UNC	7.50	48

NOTES: Sizes 6"x6" and larger are gear operated. Dimension "F" includes drain plug and support brackets.

Class 300 2"FP (in.)

Size	A	B	C	D1	E1-RF	E3-WE	F	G	H	N	M	P	L
2x2	2.00 x 2.00	3.62	6.50	NA	8.50	8.50	4.89	4.87	9.55	8	5/8-11UNC	5.00	30

NOTES: Sizes 6"x6" and larger are gear operated. Dimension "F" includes drain plug and support brackets.

